



AGM
Airfield Guidance Sign
Manufacturers, Inc.

108 Fairgrounds Drive • Suite 8
Manlius, NY 13104
Phone: 315-682-6707
Fax: 315-682-6758
www.agmsigns.com

D-Lux LED Retrofit Installation and Owner's Manual





108 Fairgrounds Drive • Suite 8
 Manlius, NY 13104
 Phone: 315-682-6707
 Fax: 315-682-6758
 www.agmsigns.com

D-Lux Retrofit Kit Catalog Numbers

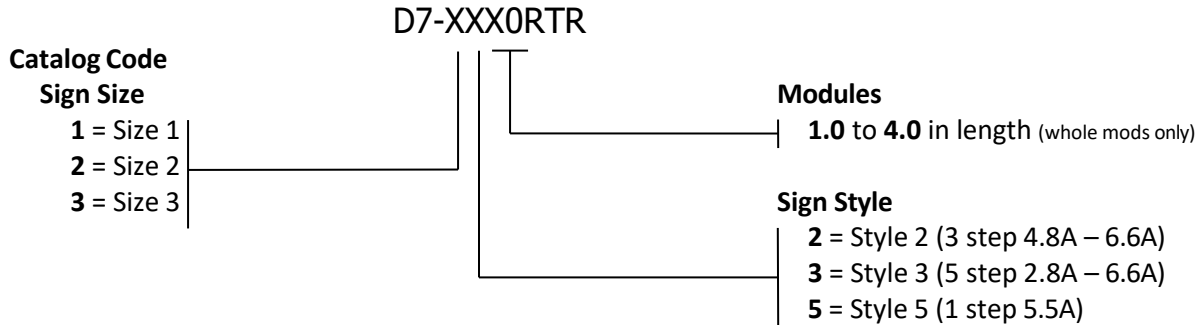

L830 Requirements, VA Loads, Power Factors¹ for LED Board Light Source

Size	Style	Modules	L830 Transformer	VA*	Power Factor*	# of Lamps
1	2 & 5	1.0	65W	39	0.93	2
1	2 & 5	2.0	65W	44	0.93	4
1	2 & 5	3.0	65W	49	0.94	6
1	2 & 5	4.0	65W	54	0.94	8
2	2 & 5	1.0	65W	41	0.93	3
2	2 & 5	2.0	65W	49	0.94	6
2	2 & 5	3.0	65W	56	0.94	9
2	2 & 5	4.0	65W	65	0.94	12
3	2 & 5	1.0	65W	44	0.93	4
3	2 & 5	2.0	65W	54	0.94	8
3	2 & 5	3.0	65W	65	0.94	12
3	2 & 5	4.0	100W	77	0.93	16
1	3	1.0	65W	39	0.93	2
1	3	2.0	65W	44	0.93	4
1	3	3.0	65W	49	0.94	6
1	3	4.0	65W	54	0.94	8
2	3	1.0	65W	41	0.93	3
2	3	2.0	65W	49	0.94	6
2	3	3.0	100W	57	0.94	9
2	3	4.0	100W	69	0.94	12
3	3	1.0	65W	44	0.93	4
3	3	2.0	65W	54	0.94	8
3	3	3.0	100W	69	0.94	12
3	3	4.0	200W	77	0.93	16

* These ratings are subject to change without notice.

¹ Power factors are measured on the primary of the corresponding L830 transformer, per FAA Circular 150/5345-44J. This takes into account the inherent deficiencies of the isolation transformer in the values.



108 Fairgrounds Drive • Suite 8
Manlius, NY 13104
Phone: 315-682-6707
Fax: 315-682-6758
www.agmsigns.com

Inspection and unpacking

When unpacking each kit, check that the LED mounting brackets are not bent or damaged from shipping. Make sure to note any damage that occurred during shipping when receiving the retrofit kit and be sure to document it with the carrier. When installing the retrofit kit, make sure that the correct L830 isolation transformer is connected.

Identify the components with different type and length wire harnesses. An inventory of each kit can be found on pages 14 to 16. Power to driver wire harnesses have **4** wires and a ferrite coil at one end, as shown on pages 5 to 8. They are already plugged into the driver modules and ready to be routed back to the power supply output. LED to LED wire harnesses have **5** wires and are plugged into the bottom of the driver modules, ready to be routed to the **IN** connection of an LED board on a mounting bracket. Additional LED to LED wire harnesses may be plugged into the **OUT** connection of a LED board on one mounting bracket to connect to an **IN** connection of an LED board on an adjoining bracket. Mounting brackets are numbered from 1 to 4; number 1 is closest to the power cord.

Useful tools to complete the retrofit are:

- Wire cutters & strippers;
- Drill with 9/64" bit and 5/16" bit;
- Countersink bit;
- #2 Phillips screwdriver and a deep 3/8" socket; and
- 5/16" nut driver.

D-Lux Retrofit Installation

1. Make sure the circuit is turned off and locked out.
2. Remove the top of sign on the module where the power cord enters. Remove the panel on the side that is easiest to work on (downwind). Replace the top after removing the panel (this will maintain the width of the module while the light bar assembly is replaced).
3. Cut or disconnect the power cord as close to the existing power control module (PCM) as possible. Leave enough slack to strip the ends and crimp on 1/4" female spade connectors.
4. Remove the existing light bar assembly from the first module where the power enters, and install the replacement light bar assembly shipped with the retrofit kit. Cut off any old wiring that extends into connecting modules. The replacement light bar assembly should be oriented with the rectifying bridge closest to the power end of the sign. Mounted on the underside of the replacement light bar assembly, the rectifying bridge is a black 1" square, 1/4" thick with 4, 1/4" spade terminals, two of which have a black and a red wire connected to the LVCV2 PCM. If the holes on the end of the light bar do not line up directly with the holes on the castings, use a 5/16" drill bit to run through the casting tabs to widen and align the holes. Insert the bolts and washers, and attach the K-Lock nuts to secure the light bar assembly to the sign module. Once secure, the top of the sign can be removed and set aside.
5. The GDT surge protector is connected to the rectifying bridge and will have two insulated 1/4" male spade terminals open where the power cord is [to be] connected. Crimp the 1/4" female spade connector terminals contained in the hardware kit on the ends of the power cord that have been stripped back 1/4" from where they were cut. Connect the male terminals of the GDT to the female terminals of the power cord.



6. The LED brackets are attached across the top of the sign module. Begin by drilling out the existing rivets and speed nut screw clips on the top of the module castings. After the rivets and the speed nut screw clips are removed, countersink the hole to accommodate the new screw head. Holes may already be countersunk (a). Just make sure the tops of the 6 x 32 flat head screws lie at or below the casting surface before continuing.

7. Insert the 6 x 32 flathead screws from the hardware kit into the holes.

8. Bring the LED mounting bracket into the module (note which direction to insert it based on the wiring diagrams on the next page), and raise it up to the top of the module (b) so the screws are extending through the recesses on either side of both ends. This is best accomplished with an assistant to hold the LED mounting bracket in place while the next steps are completed.

9. With the LED mounting bracket held in place, insert the replacement speed nut screw clips on the protruding screw ends, and secure them in place using the nylon lock nuts from the hardware kit.

10. Using a 5/16" nut driver (or wrench), tighten the screw so the tip of it just passes through the nylon retainer of the nut. It is important not to tighten the speed nuts too much in order for the speed nut clip to find the speed screw easily. The whole assembly will be secure when the thumb screws that hold the tops on are tightened (c).

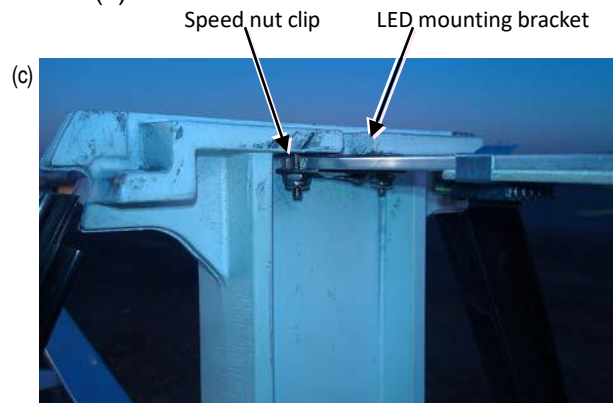

11. Connect the 5 wire LED to LED harnesses from the driver module, up the tree castings and into the **IN** connection of the first LED mounted on the LED light bracket, per the wiring diagrams on pages _ to _. Note any configuration where one LED light bracket connects to the next between modules using the 12" five wire harnesses.

12. If more than one driver is required for the retrofit, note in which module it is located as described on the wiring diagram, and follow the same procedure from step 4 to install it. Note on the wiring diagram, upon which end the driver is located. Connect the additional driver to the LVCV2 power supply using the 4 wire power to driver wire harnesses, making sure to plug the 1/2" ferrite end of the wire harness into the LVCV2 and the other end into the single plug location on the driver.

13. Plug the additional LED light brackets into the extra drivers on all the connections per the drawing.



108 Fairgrounds Drive • Suite 8
Manlius, NY 13104
Phone: 315-682-6707
Fax: 315-682-6758
www.agmsigns.com

14. Restore power to the sign, and verify operation.
15. When operation is confirmed, use the u-clips included in the hardware kit to secure any slack wire to the light bar assemblies.
16. Replace panels and secure the tops of the sign.

D-Lux LED Maintenance

AGM signs are designed to provide years of trouble-free service. Prior to the performance of any work on the signs, power must be disconnected and locked out at the vault. We recommend an annual inspection & wiping down of the sign interior to maintain bright and even light output. Inspection of the signs should also include removal of any excess dirt, snow, and avian excrement to maintain proper visibility of the sign legend.

[REMAINDER OF PAGE INTENTIONALLY BLANK]



D-Lux LED Wiring Diagram

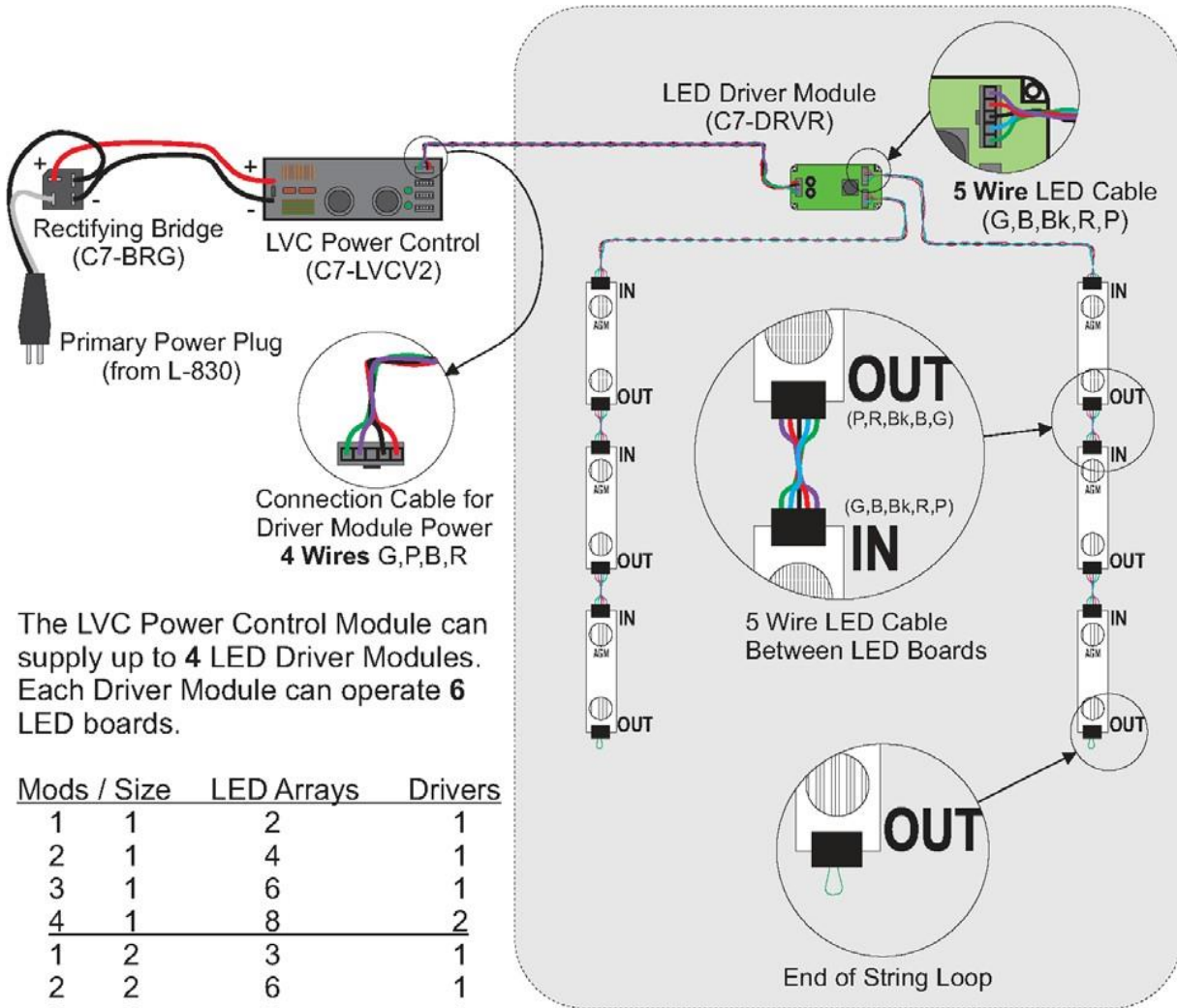

The LVC Power Control Module can supply up to 4 LED Driver Modules. Each Driver Module can operate 6 LED boards.

Mods / Size	LED Arrays	Drivers
1 1	2	1
2 1	4	1
3 1	6	1
4 1	8	2
1 2	3	1
2 2	6	1
3 2	9	2
4 2	12	2
1 3	4	1
2 3	8	2
3 3	12	2
4 3	16	3
1 5	4	1

**LED Light Engine Assembly
(D-Lux Size 2, 2Mod pictured,
[3 LED boards / module])**



AGM D-Lux LED Size 1 Wiring Schematic

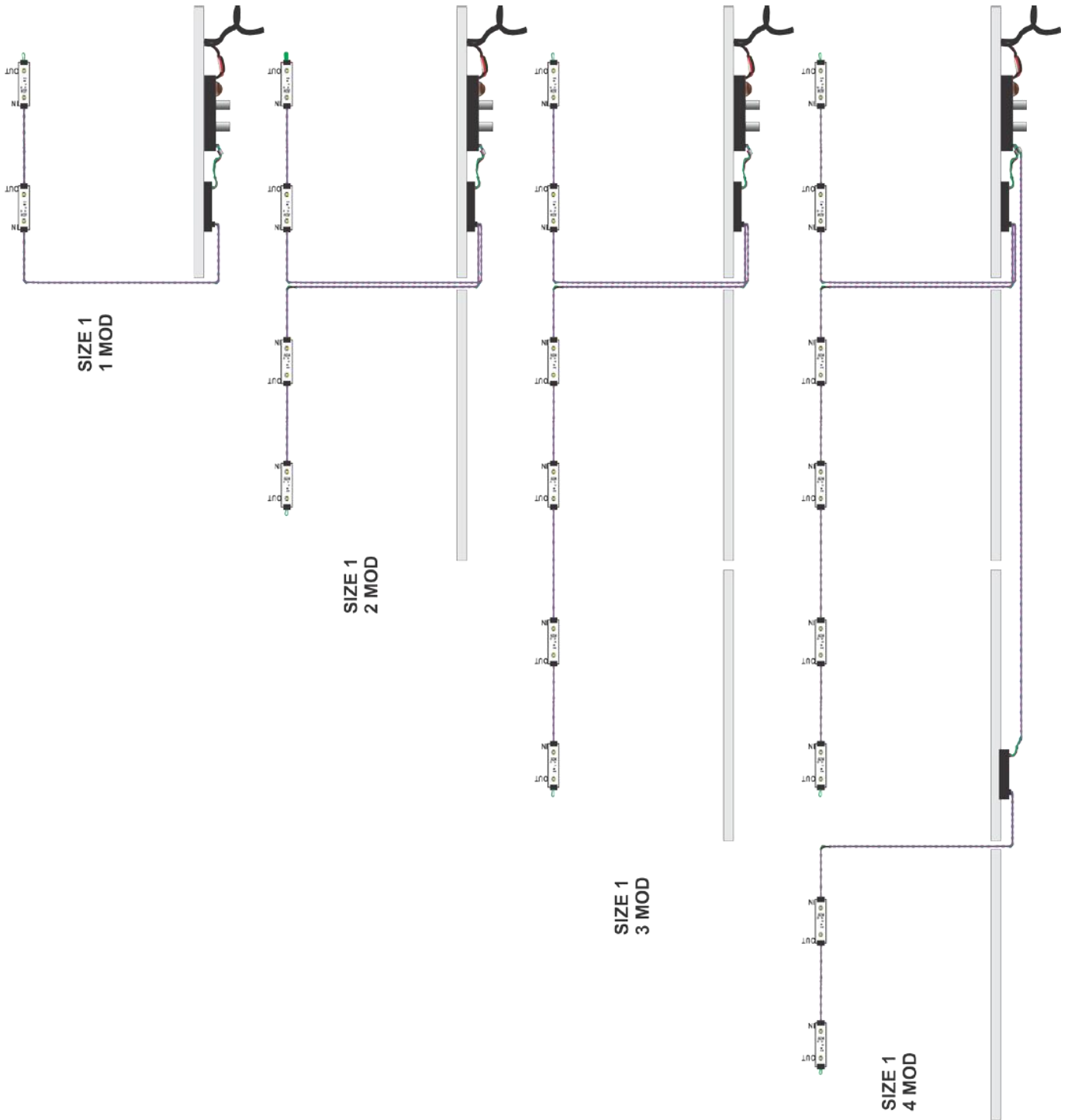



AGM D-Lux LED Size 2 Wiring Schematic

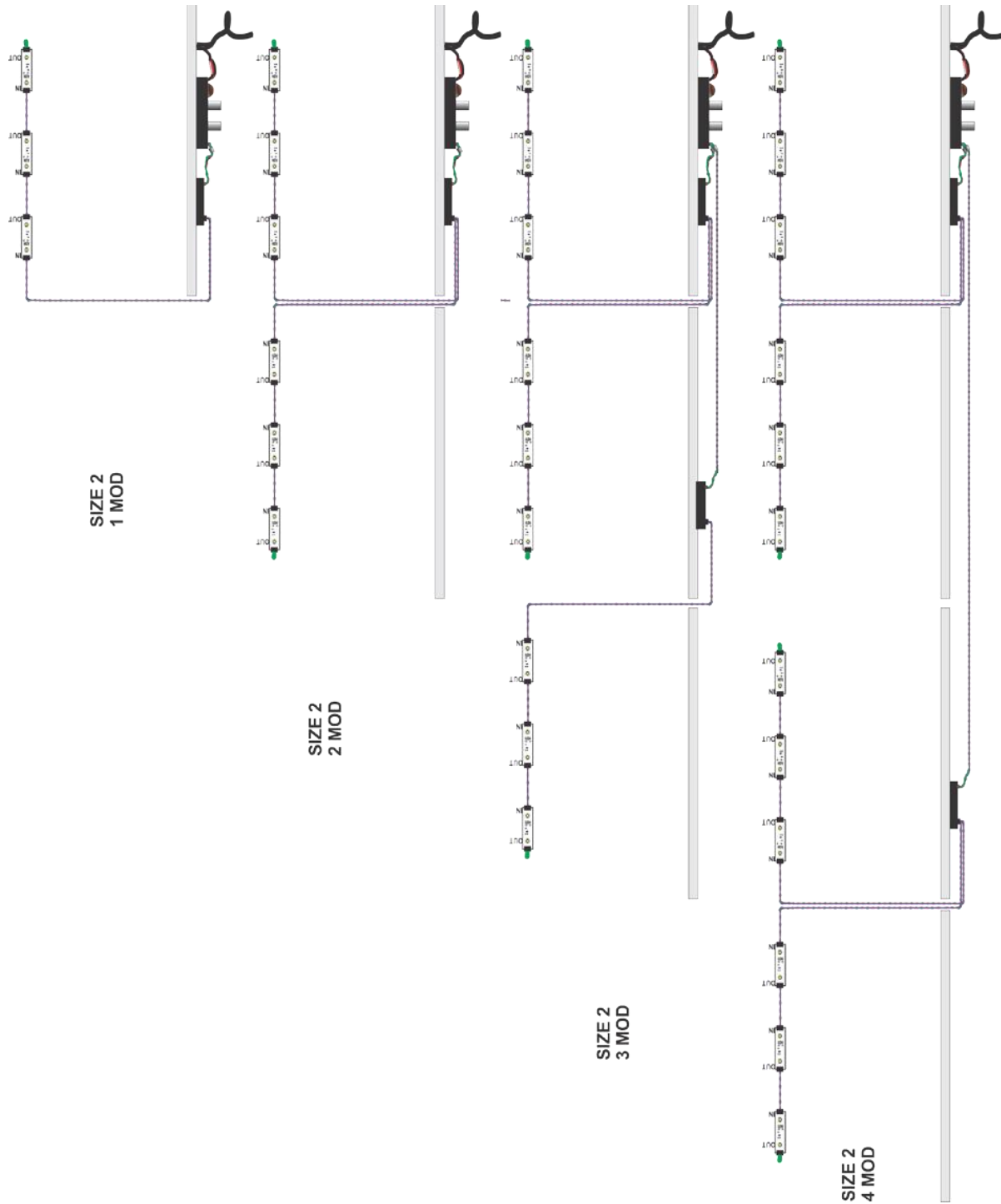



AGM D-Lux LED Size 3 Wiring Schematic

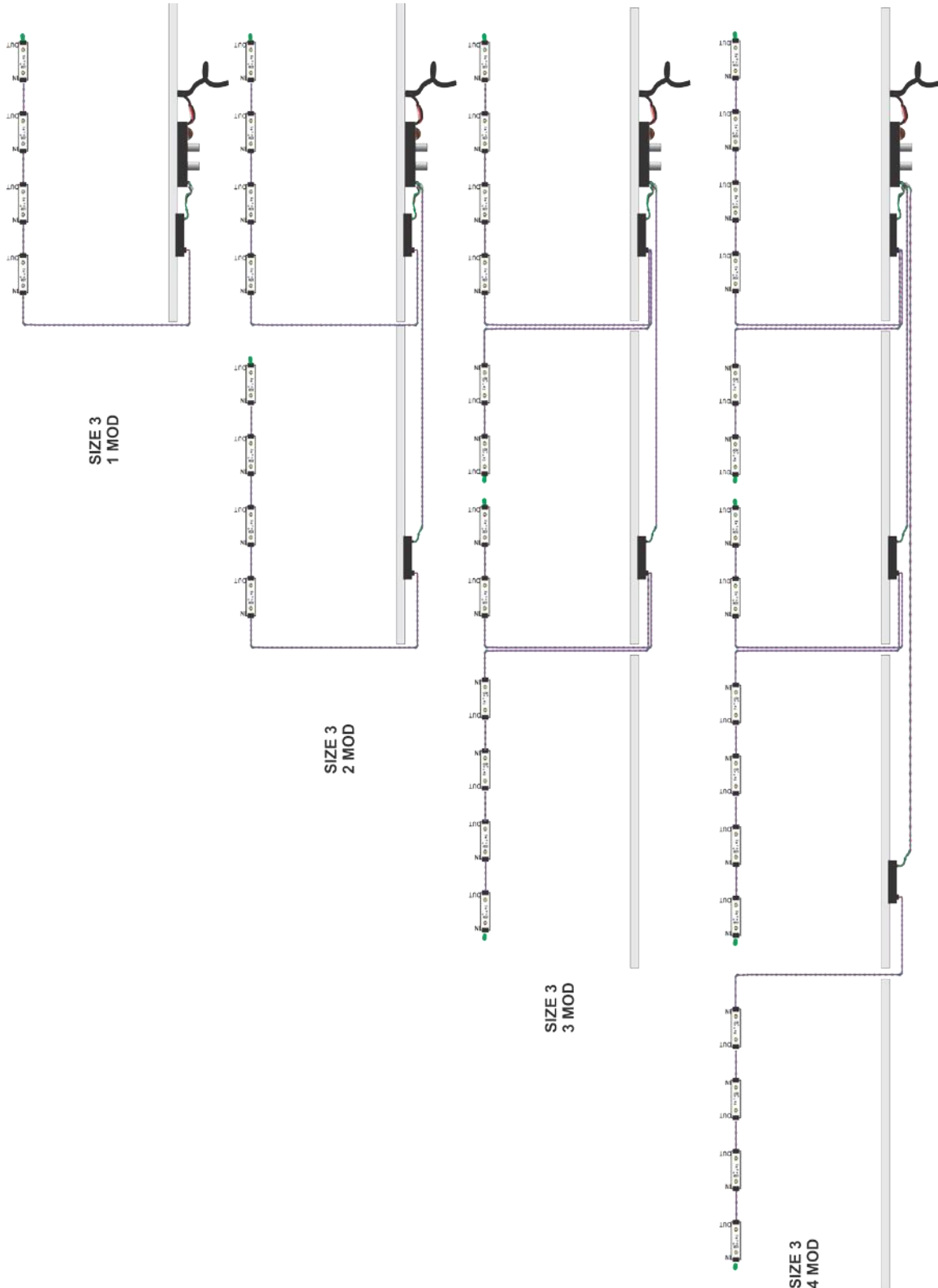



D-Lux Sign Dimensions

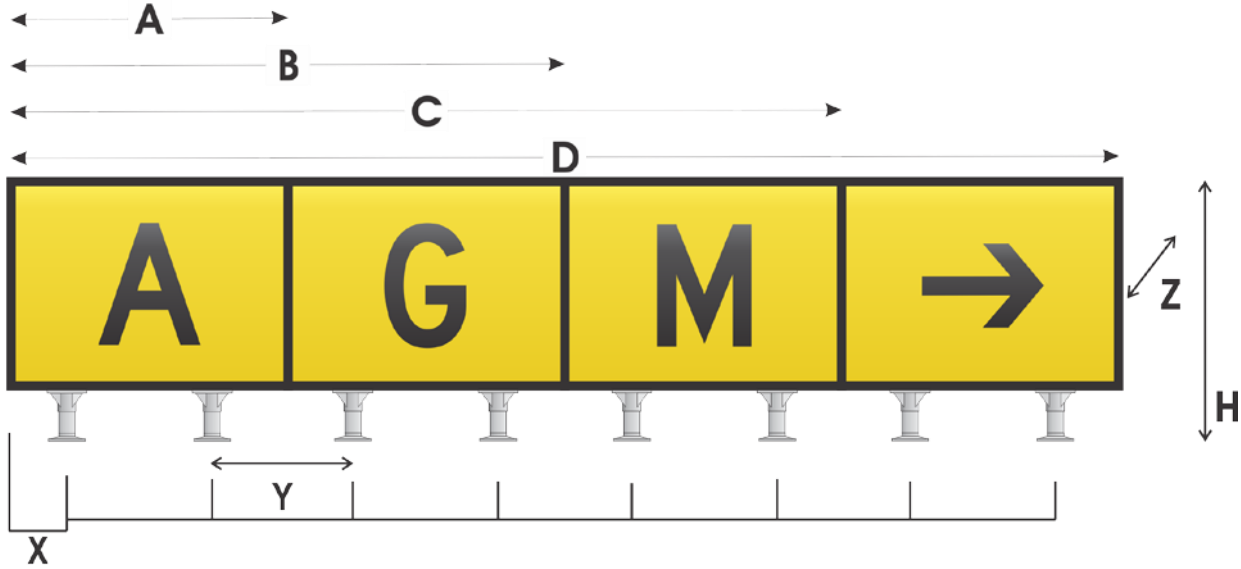

	A	B	C	D	X	Y	Z	H
Size 1	30.0	59.0	88.0	117.0	7.75	14.63	13.0	26.5
Size 2	37.5	73.75	110.0	146.3	9.125	18.5	14.63	32.75
Size 3	41.88	83.75	125.6	164.5	10.5	21.0	15.88	38.5
Size 5	41.88	na	na	na	10.5	21.0	15.88	38.5

- A = length of one module
- B = length of two modules
- C = length of three modules
- D = length of four modules
- X = length from end of sign to first frangible leg
- Y = length between frangible legs
- Z = maximum sign width
- H = maximum sign height

Floor Flange Dimensions

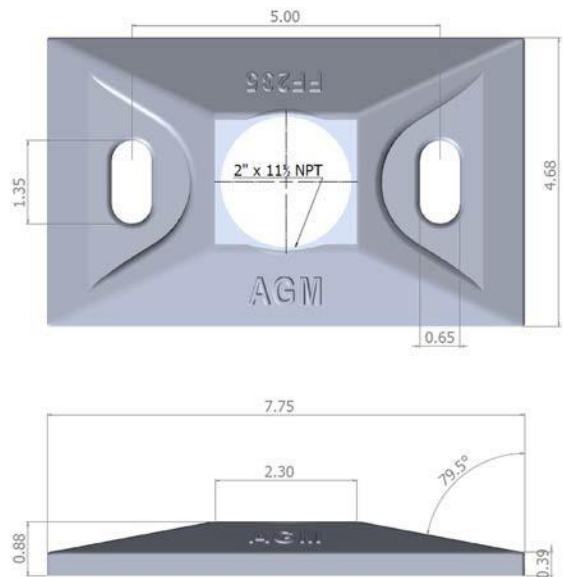



108 Fairgrounds Drive • Suite 8
Manlius, NY 13104
Phone: 315-682-6707
Fax: 315-682-6758
www.agmsigns.com

D-Lux LED Board Operation

AGM's LED board light engine uses high efficiency LEDs to illuminate the guidance sign. Once the circuit is energized, there is a 4 second delay before the light engine turns on; this is normal. If there is an interruption in power, there could be another identical delay indicating the startup sequence has cycled. There are 2 high brightness LEDs on each board. Per FAA Engineering Brief #67, if more than 25% of the alternate lighting devices (LEDs) are not lit, the LED board must discontinue operation and communicate its condition within the sign, causing the whole sign to turn off. The FAA requires this to make sure an incorrect message is not displayed that could cause a safety issue to traffic on the airfield. Each LED board has a monitor circuit to verify operation. The LED board that has detected the problem will illuminate a red LED on the board indicating it has a problem and should be replaced.

D-Lux LED Board Troubleshooting

All AGM signs have been tested at the factory and set to function within FAA specifications. Installation and operation issues most frequently trace to an undersized isolation transformer or to damage during shipping. Before commencing repairs, please contact AGM (315-682-6707 or via email) with the catalog number and serial number from the name plate of the malfunctioning sign to determine warranty coverage. If the LED boards and isolation transformer appear functional, and any operating issues have not been resolved after following the troubleshooting guidelines, please contact AGM; we will be pleased to assist you. We keep parts in stock and ship within 24 hours.

BEFORE PERFORMING MAINTENANCE ON AN AIRFIELD GUIDANCE SIGN, VERIFY THE SIGN'S CIRCUIT IS OFF AND LOCKED OUT FROM ACCIDENTAL ENERGIZATION.

1. Verify that the amp reading (taken on one of the sign input power cords) reflects the amperage of the airfield circuit. If the reading is not identical, then there could be a problem with the isolation transformer or regulator providing power to the sign. Lock out the circuit and verify the condition of the isolation transformer for the sign.
2. Ensure that power to the sign has been turned off. To inspect the operation and determine why a D-Lux sign has malfunctioned, open the top by removing the thumb screw on either side of each modular section of the top of the sign. Remove one legend panel by pulling directly up.
3. Inspect the LED boards that are mounted on the mounting brackets. Cycle the power to the sign remotely or by using the optional isolating safety switch on the sign. If there is a fault with an individual LED board, all the LEDs should light up and then shut down within a second. The malfunctioning LED board will have an illuminated red LED directly on the circuit board as an indication that it or the driver circuit has malfunctioned.
 - a. To isolate the malfunction, remove the end loop plug from the end of the LED circuit where the red light was observed. Disconnect that string of LED boards from the driver and insert the end loop plug in its place on the driver. Cycle the power again and observe whether all remaining lights in the sign illuminate normally.
 - i. If all the lights remain on normally, there is a problem with a LED board on the string that was disconnected. Power off the sign, replace the bracket with the malfunctioning LED board, return the end loop to the OUT plug, and connect the LED bracket circuit to the driver again. Power on the sign, verify normal operation, and take the affected bracket back to the shop to isolate the indicated LED board



108 Fairgrounds Drive • Suite 8
Manlius, NY 13104
Phone: 315-682-6707
Fax: 315-682-6758
www.agmsigns.com

for replacement. Instructions for replacing the LED board are on the following page.

- ii. If all the lights go out again and the red light appears on the remaining string plugged into the driver, then the driver needs to be checked. Power off the sign, unplug the power cable that runs from the power control module (PCM) to that driver, cycle the power to the sign, and confirm the other lights and driver circuits in the sign remain lit. If so, the disconnected driver needs to be replaced and the strings of LEDs connected to the new driver to confirm their operation.
- b. If the remaining driver circuits are still not operational on restart, power off the sign, and unplug all the drivers from the PCM. With all driver circuits unplugged, power up the sign and make sure the PCM has both green LEDs. If one or both green LEDs on the PCM are not illuminated, skip the next step below.

IMPORTANT: DO NOT PLUG DRIVER CIRCUITS INTO AN ENERGIZED LVC POWER SUPPLY WHEN TROUBLESHOOTING.

- i. With the sign powered down, plug in the driver circuits individually and power on the sign to confirm their individual operation. If another driver circuit is found to be causing shut down, repeat the previous steps to isolate the cause.
- c. Next, ensure the bridge rectifier is functioning properly by taking a DC voltage reading across the red and black wires exiting the bridge rectifier. With the circuit off and locked out, note the position of where the wires connect on the terminals and then remove them from the connecting posts of the bridge rectifier. The corners with red and black wires are the DC output of the bridge rectifier. The positive red (+) wire is always connected to the terminal that is 90° different in orientation than the others and is located on the small diagonal corner of the bridge rectifier.
 - i. Using an RMS multi-meter, set the operation for diode testing and place the black negative lead on the positive terminal of the bridge rectifier, and the red positive lead on the negative terminal of the bridge rectifier in the corner opposite the positive terminal.
 - ii. If the meter reads close to 0.90V_{DC} to 1.00V_{DC} the bridge rectifier is good. If it reads approximately 0.40V_{DC} to 0.60V_{DC} the bridge rectifier is bad and needs to be replaced.
- d. If the bridge rectifier is good, the next step is to check the output of the PCM. There are 2 green LEDs on the PCM near the output connections and if both of these are not illuminated when the sign is powered on and all circuits are disconnected, the PCM needs to be replaced. If both are illuminated, check the output voltage by setting a true RMS meter to DC voltage, and insert the black negative probe where the green wire connects and the red positive probe where the red wire connects. The output voltage should be approximately +50V_{DC}. If there is no voltage here, the PCM needs to be replaced.
 - i. After the PCM is replaced, follow the driver circuit checking procedure from the preceding page. Take note of the green LED lights on the PCM; and if on start up,



108 Fairgrounds Drive • Suite 8
Manlius, NY 13104
Phone: 315-682-6707
Fax: 315-682-6758
www.agmsigns.com

one of the LEDs is not illuminated, turn off the power promptly and replace the driver of the circuit being checked. Do not run a new PCM with a bad driver as damage to the PCM can occur.

D-Lux LED Board Replacement

Replacement of a nonfunctioning LED board is best accomplished inside the electrical shop, after swapping out mounting brackets. To replace the LED board, carefully remove the black wire harness plugs, press on the release safety catches of the plugs and pull out along the same plane that the LED is mounted on. Remove the mounting clips on either side of the LED board. Then using a sharp blade, slide under the LED board and pry the LED board off of the mounting bracket where the LED board is held with thermal transfer adhesive. Make sure to clean the area of the mounting bracket where the LED board was mounted before attaching a new one.

On the replacement LED board, strip the protective cover from the thermal adhesive on the back and carefully place the LED board in the same location as the previous LED board. Make sure to align the IN side and OUT side in the same orientation as the other LED boards on the mounting bracket. Replace the wire harness connections; and if the replacement LED board is at the end of the string, insert the green, end loop plug that completes the circuit.

[REMAINDER OF PAGE INTENTIONALLY BLANK]

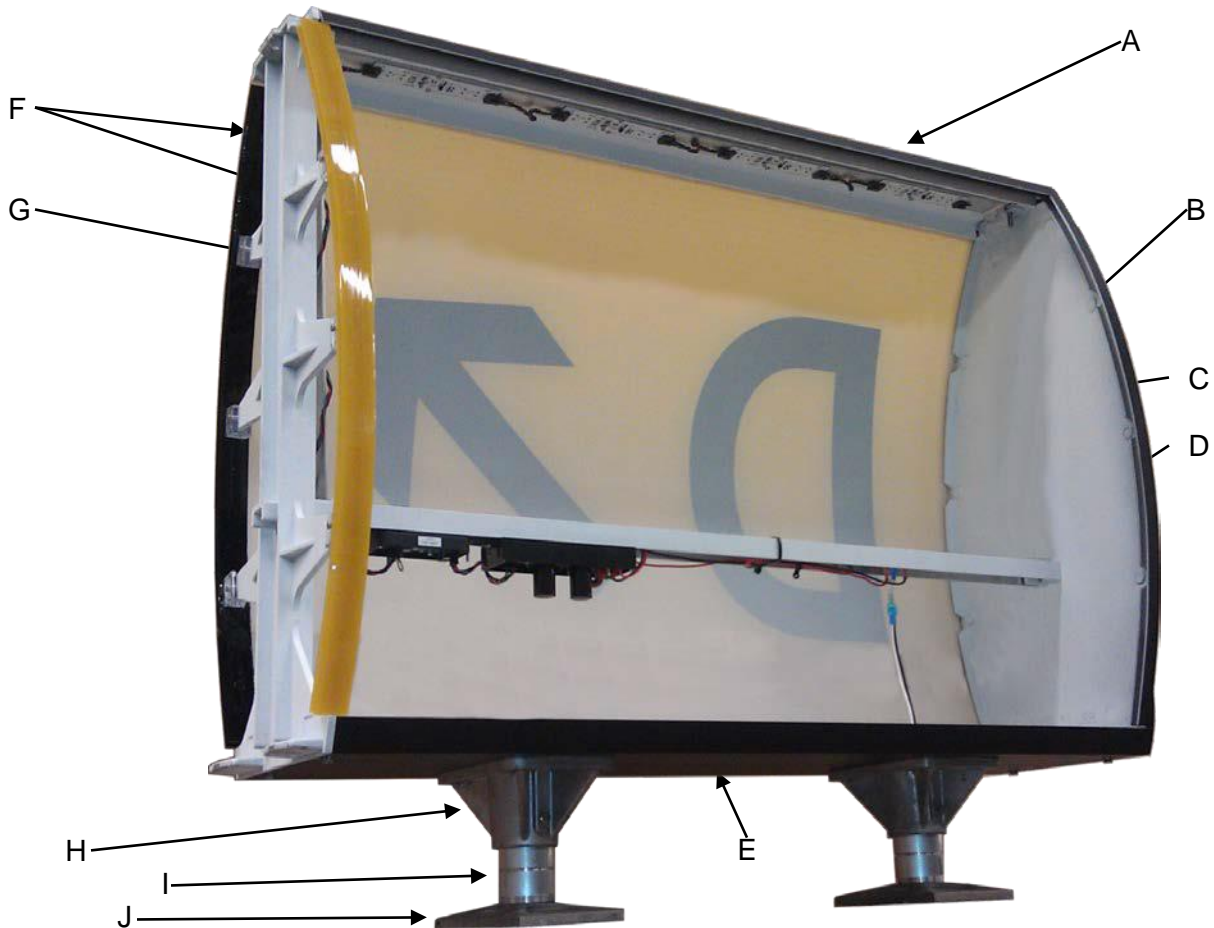

	Part #	Description		Part #	Description
A	D6-S#TP	Top	K	C7-LEDV2	LED modules
B	D6-S#EC	End	L	D7-LB#	LED Bare w/ LED
C	D8-D#4LP	Legend panel	M	C7-DRVR	LED driver module
D	D6-SXUB	U Bar	N	C7-LVCV2	Low voltage power control module
E	D6-S#B	Bottom	O	C7-BRG	Bridge rectifier (obscured)
F	D6-S#R	Panel joint*	P	C7-60PC	Power cord
G	D6-S#TC	Modular connector		D6-DTSC	Speed nut screw clip (not pictured)
H	C6-SF6	Slip flange		D6-DTS	Thumb screw (not pictured)
I	D6-DC#	Frangible coupling		C6-THR	Tether (not pictured)
J	C6-FF235	Floor flange			

When ordering:
= sign size;
* = specify color (black, red, yellow)



108 Fairgrounds Drive • Suite 8
 Manlius, NY 13104
 Phone: 315-682-6707
 Fax: 315-682-6758
 www.agmsigns.com

D-Lux LED Retrofit Kit Parts List Size 1 Signs

The retrofit kits for size 1 signs include:

Sign Length:	1.0	2.0	3.0	4.0
LVC & Driver Mounted Light Bar Assembly	1	1	1	1
Driver Mounted Assembly	-	-	-	1
D-Lux Size 1 LED Light Bracket	1	2	3	4
5" LVC to Driver Wire Harness	1	1	1	1
62" LVC to Driver Wire Harness	-	-	-	1
5" LED to LED Wire Harness	1	2	3	4
25" LED to LED Wire Harness	1	2	2	3
12" LED to LED Wire Harness			1	1
LED End Loop	2	2	2	4
Wire Harness U-Clip	3	4	6	8
6" Wire Zip Tie	1	1	1	1
Speed Nut Screw Clip	2	4	6	8
6 x 32 Philips Flathead 3/4"	4	8	12	16
6 x 32 Nylock Insert Nut	4	8	12	16



108 Fairgrounds Drive • Suite 8
 Manlius, NY 13104
 Phone: 315-682-6707
 Fax: 315-682-6758
 www.agmsigns.com

D-Lux LED Retrofit Kit Parts List Size 2 Signs

The retrofit kits for size 2 signs include:

	Sign Length:			
	1.0	2.0	3.0	4.0
LVC & Driver Mounted Light Bar Assembly	1	1	1	1
Driver Mounted Assembly	-	-	1	1
D-Lux Size 2 LED Light Bracket	1	2	3	4
5" LVC to Driver Wire Harness	1	1	1	1
50" LVC to Driver Wire Harness	-	-	1	1
5" LED to LED Wire Harness	2	4	6	8
12" LED to LED Wire Harness	-	-	-	1
31" LED to LED Wire Harness	1	2	3	3
LED End Loop	2	2	4	4
Wire Harness U-Clip	3	5	7	9
6" Wire Zip Tie	1	1	1	1
Speed Nut Screw Clip	2	4	6	8
6 x 32 Philips Flathead 3/4"	4	8	12	16
6 x 32 Nylock Nut	4	8	12	16



108 Fairgrounds Drive • Suite 8
 Manlius, NY 13104
 Phone: 315-682-6707
 Fax: 315-682-6758
 www.agmsigns.com

D-Lux LED Retrofit Kit Parts List Size 3 Signs

The retrofit kits for size 3 signs include:

Sign Length:	1.0	2.0	3.0	4.0
LVC & Driver Mounted Light Bar Assembly	1	1	1	1
Driver Mounted Assembly	-	-	1	2
D-Lux Size 3 LED Light Bracket	1	2	3	4
5" LVC to Driver Wire Harness	1	1	1	1
50" LVC to Driver Wire Harness	-	1	1	1
94" LVC to Driver Wire Harness	-	-	-	1
5" LED to LED Wire Harness	3	6	8	11
31" LED to LED Wire Harness	1	2	4	5
LED End Loop	2	4	4	6
Wire Harness U-Clip	3	5	7	9
6" Wire Zip Tie	1	1	1	1
Speed Nut Screw Clip	2	4	6	8
6 x 32 Philips Flathead 3/4"	4	8	12	16
6 x 32 Nylock Nut	4	8	12	16