

AGM

315.682.6707

www.AGMsigns.com

GENERAL INFORMATION

For those seeking a truly modular sign, or preferring to maintain a uniform look where rounded airfield signage is already installed, AGM is pleased to offer the patented D-Lux. The D-Lux is a formidable upgrade from standard curved signs. The appearance may be familiar, but the high quality and thoughtful engineering is refreshingly new.

Each module of a D-Lux sign is mounted on an evenly spaced pair of legs. The D-Lux slip-flanges hold the legs secure with almost no gap in the assembly. Environmental forces are shared by the legs and cabinet, and not concentrated on the hardware.

On a D-Lux, each rounded face is made from expertly formed acrylic. Size 1 and 2 signs have available the optional Herculens panel, which is CNC machined from 3/8" thick acrylic and is factory installed on our Size 3 D-Lux. This allows our Size 3 D-Lux to shed jet blast without the use of bothersome flimsy plastic internal bracing or gimmicky cabinet "upgrades" employed by others.

Connecting the legend panels on the D-Lux are translucent panel joints, which are welded together with adhesive and then additionally reinforced with stainless steel hardware.

Every D-Lux module features a top that is designed to easily guide the top edge of panels into place when it is replaced after re-lamping, and is fixed to the sign with two turn fasteners. No tools are required for re-lamping, and the D-Lux uses familiar and inexpensive 6.6A 45W lamps, either quartz or incandescent. Configurations using miniature 12v 20w lamps are also available.

The D-Lux base model brightness controls use familiar technology that has been proven for years in the field. Better, the D-Lux also features AGM's Style U power control system as an option - a passive, non-inductive design that exhibits near-unity power factors on all regulator steps.

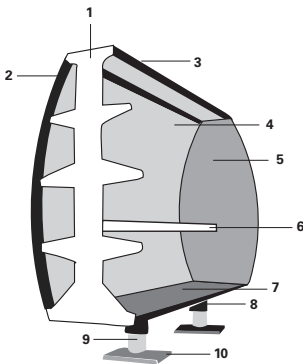

Body Components

- 1: Support Junction
- 2: Panel Joint
- 3: Top
- 4: Panel
- 5: End
- 6: Lamp Mounting Bar
- 7: Bottom
- 9: Frangible Coupling

Face Components

- 2: Panel Joint
- 4: Panel

Universal Components

- 8: Slip Flange
- 10: Floor Flange

